

REVISION HISTORY				
REV	DESCRIPTION	ECN	DATE	APPROVED
D	IT #23 WAS 99-104-00-9012	D1514	12JA05	NN

Parts List			
QTY	PART NUMBER	DESCRIPTION	ITEM
1	LABEL-003	FOOTAGE NAME PLATE	44
8	B140-101	DRIVE SCREW DIA 0.152 X 1/2" LG	43
4	B140-100	WEAR PLATE	42
4	A076-11	CLAMP HINGE	41
4	B142-11	UPPER PIPE CLAMP	40
4	B141-11	LOWER PIPE CLAMP	39
12	H042-50	PIN, GROOVE TYPE C, 5/16 X 1.5" LG	38
4	A049-15	LOCK DOWN KNOB NUT	37
1	B081-11	SPRING PLUNGER, VLIER #SL312	36
1	T481-43	SPRING, SPAE-NAUR #B636	35
1	99-165-00-1220	DOWEL PIN 3/16 X 1.25" LG	34
2	99-106-01-0412	SHCS 1/4-20 X 3/4" LG STAINLESS STEEL	33
1	B079-11	LOCK PLATE	32
2	99-165-00-2416	DOWEL PIN 3/8 X 1" LG	31
4	99-141-00-0005	WASHER, 5/16 ID FLAT	30
4	99-138-100-0005	ACORN NUT 5/16-18UNC	29
4	B280-516	CARRIAGE BOLT 5/16-18UNC X 3/4" LG	28
2	B103-53	FLANGE BEARING NKS, UPFL205-16S	27
2	99-111-00-0616	FHCS 3/8-24UNF X 1" LG	26
2	B156-11	LEG SUPPORT	25
1	B117-11	ACTUATOR SHAFT	24
16	99-106-00-9012	SHCS 10-24UNC X 3/4" LG	23
1	B205-12	TRACK, RH	22
1	B205-11	TRACK, LH	21
2	99-130-00-0006	NUT, NYLOCK 3/8-24UNF	20
6	B200-42	GUIDE WHEEL (DUAL-VEE, SIZE 2)	19
3	B103-65	CONCENTRIC WHEEL SHAFT	18
3	B103-64	ECCENTRIC WHEEL SHAFT	17
6	99-176-00-0601	WASHER, THRUST .375 ID X .0325 TH	16
12	99-132-00-0006	JAM NUT 3/8-24UNF	15
4	99-106-00-0820	SHCS 1/2-13UNC X 1.25" LG	14
4	99-106-00-0824	SHCS 1/2-13UNC X 1.5" LG	13
1	B284-11	SUPPORT LEG R.H	12
1	B284-11	SUPPORT LEG L.H	11
22	99-110-00-0410	FHCS 1/4-20UNC X 5/8	10
1	B078-11	LOCK BODY	9
4	A024-15ASM	LOCK DOWN KNOB ASSEMBLY	8
1	B285-11	LOCKING PIN	7
1	99-163-00-0808	ROLL PIN, 1/8 X 1/2" LG	6
6	99-110-00-9010	FHCS 10-24UNC X 5/8	5
1	B132-01	SPROCKET	4
1	B283-11	TOOTH RACK	3
1	B282-11	BED	2
1	B281-11	CLAMPING MOUNTING PLATE	1

DRAWN nguyenj	7/23/2009
CHECKED	
QA	
MFG	
APPROVED nguyenj	
REMOVE ALL SHARP CORNERS UNLESS SPECIFIED OTHERWISE	

**FOOTAGE TOOLS INC.**

TITLE  
**B280-01 ASSEMBLY DWG  
6" MANUAL BUTT FUSION**

SIZE C	DWG NO B280-01A	REV D
SCALE NTS	SHEET 1 OF 1	

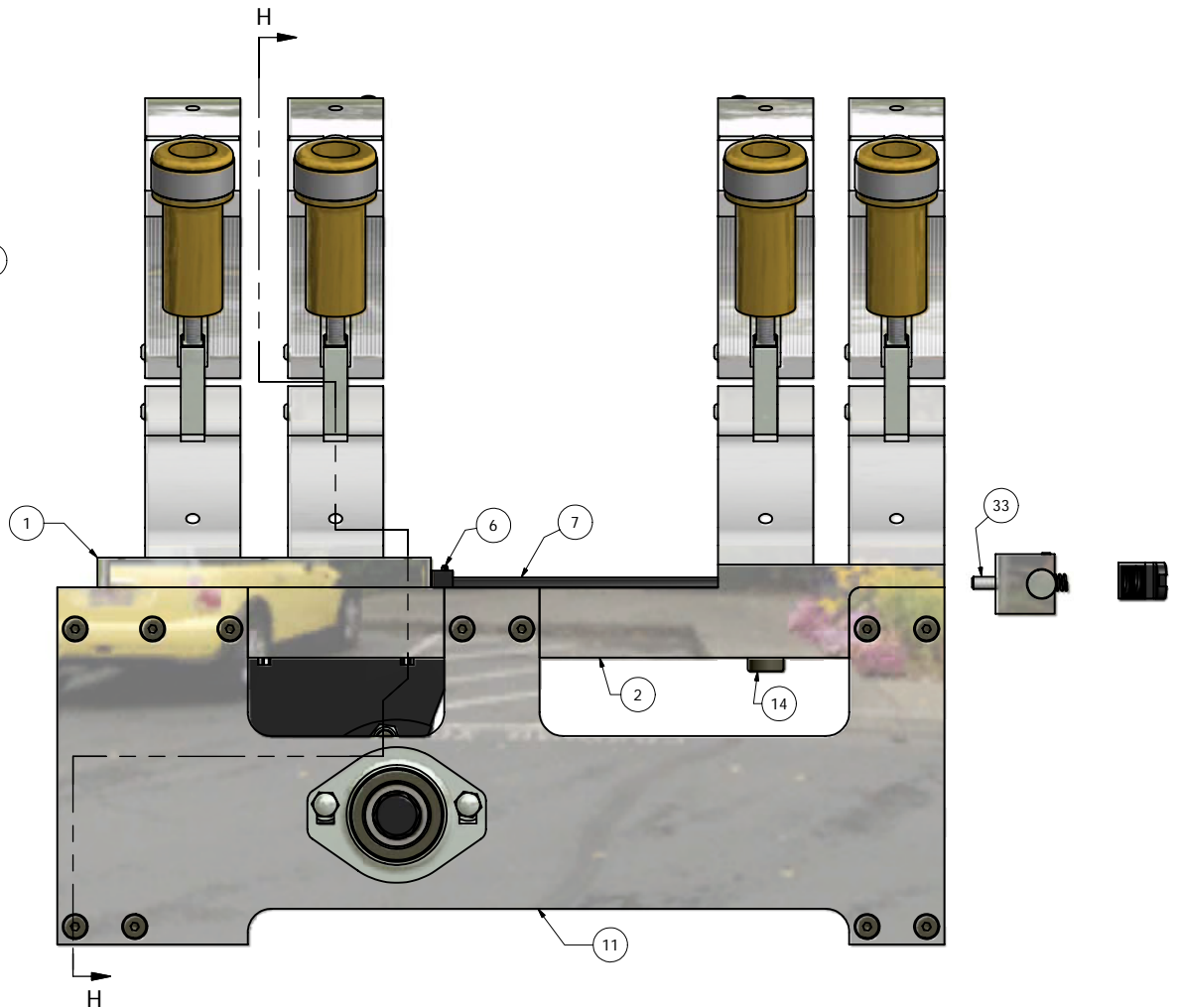
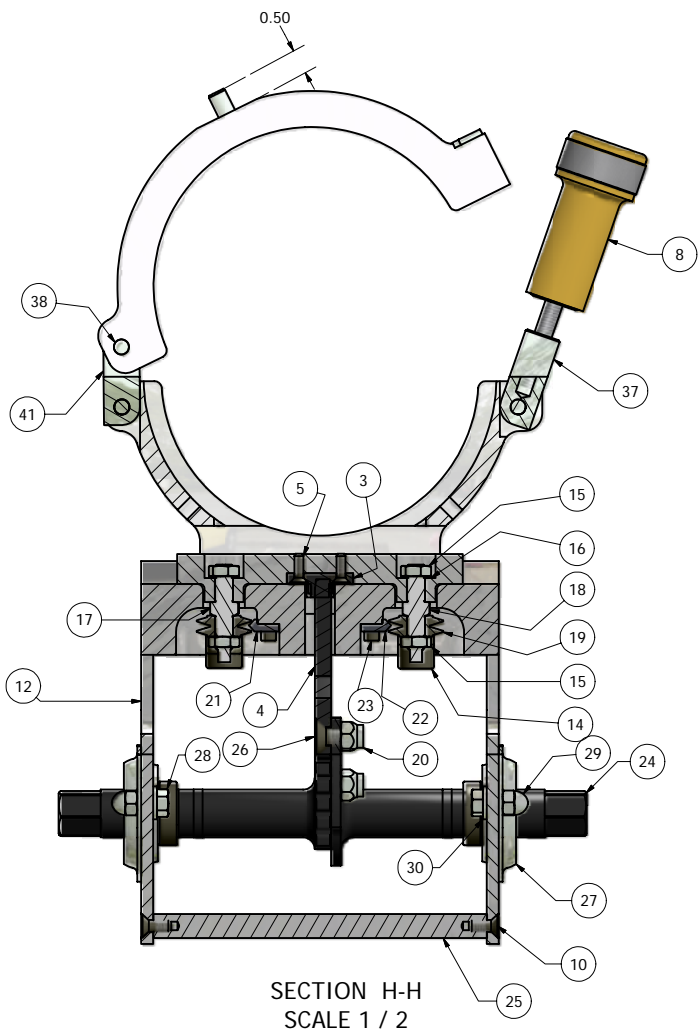

DRAWN nguyenj	7/23/2009	<b>FOOTAGE TOOLS INC.</b>	
CHECKED		TITLE	
QA		<b>B280-01 ASSEMBLY DWG</b>	
MFG		<b>6" MANUAL BUTT FUSION</b>	
APPROVED		SIZE C	DWG NO B280-01B
REMOVE ALL SHARP CORNERS UNLESS SPECIFIED OTHERWISE		SCALE NTS	REV
		SHEET 1 OF 1	